

NERAK HEAVY-DUTY S-SHAPED CONVEYORS

VERTICAL CONVEYORS FOR EURO PALLETS

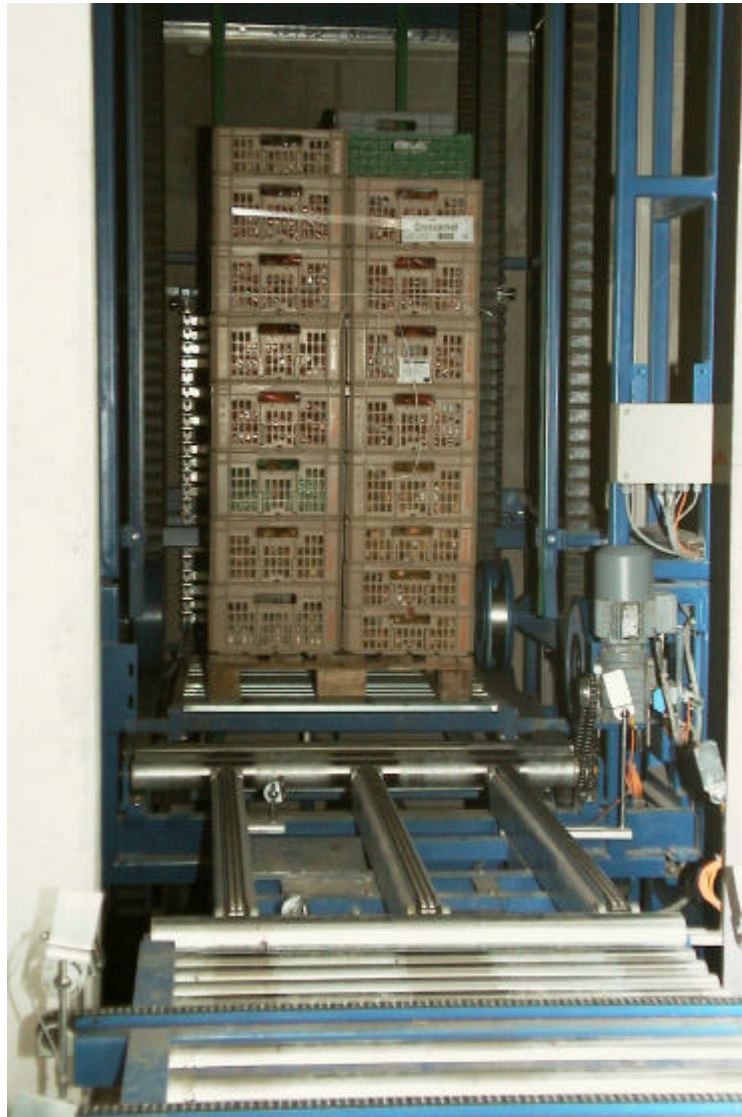

NERAK
FÖRDERTECHNIK

THE EXPERTS IN VERTICAL CONVEYING

PRINCIPLE

For many years NERAK S-shaped conveyors have been the classic choice when it comes to conveying a large quantity of packaged goods between two levels. They are characterized by reliable operation 24 hours a day, and are employed in postal sorting offices, airports, distribution warehouse and automotive factories for example.

Over the years, greater demands have been made on the S-shaped conveyor, calling for increased capacities and heavier individual loads at the same time. NERAK has met this challenge by developing the heavy-duty series S 631/55/100 for individual loads of 2 t at throughput rates of up to 400 pallets per hour at lifting heights of up to 20 m.

As with the standard S-shaped conveyor, the pallets are loaded onto the heavy-duty conveyor by means of a roller conveyor or chain conveyor that feeds the material onto the conveyor either in upward or downward direction. The material is received on a platform of steel profiles and transferred to the discharging conveyor at the point of discharge.

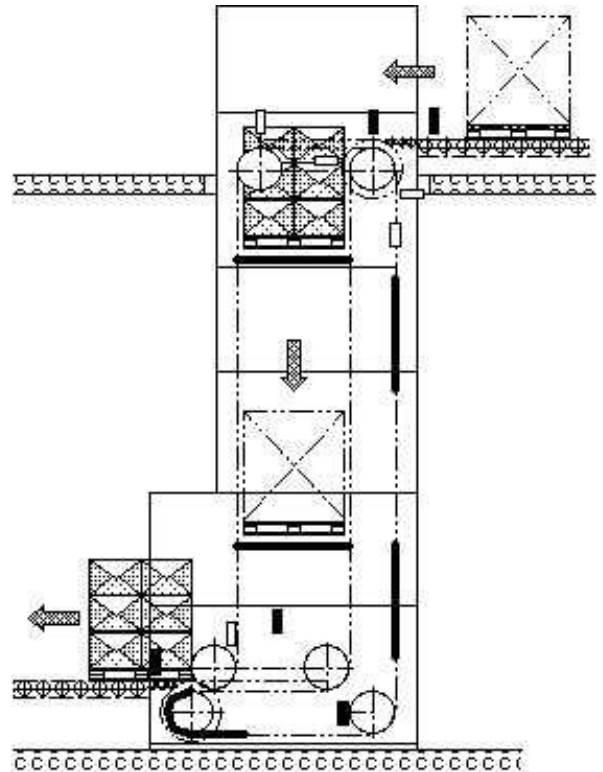

DRIVE SYSTEM

At the heart of every NERAK conveyor drive system is the heavy-duty rubber block chain.

The outstanding features of this chain are that it has no links, is silent-running, wear-resistant and maintenance free, all excellent qualities further enhanced by its corrosion-free design.



Thanks to the silent operation of the rubber block chain, there is no noise annoyance at the workstations in the immediate vicinity of the heavy-duty conveyor. Moreover, operation with the rubber block chain is extremely cost-effective as there is no need for lubrication, regular adjustment and re-tensioning. Maintenance costs are thus reduced to a minimum.

The rubber block chain is available in a number of rubber compounds to suit every application. Preference is given to the abrasive-resistant SBR compounds or in oily environments Neoprene. The rubber block chain gets its high tensile strength from embedded vulcanized steel cables.

NERAK developed the rubber block chain type 55/100 specially for the heavy-duty conveyor. This particular chain has all the qualities of the other rubber block chains, combined with an extremely high carrying load.

DESIGNS



Design for Euro pallets



Design for roller pallets

The supporting frame of the heavy-duty conveyor is a robust construction made from aluminium profile sections that are bolted together. In compliance with local requirements, it is provided with cladding of perforated aluminium sheets. Generously sized access doors allow easy access for maintenance and cleaning. The conveyor platforms of steel profiles are mounted on the rubber block chains. A spur-gear motor drives the shaft via a transmission chain. The drives are designed for operation with a frequency converter to provided by the customer. The switchgear can be wired to terminal boxes. Optional equipment available are the PLC control as well as the feeding and discharging conveyors.

DIMENSIONS

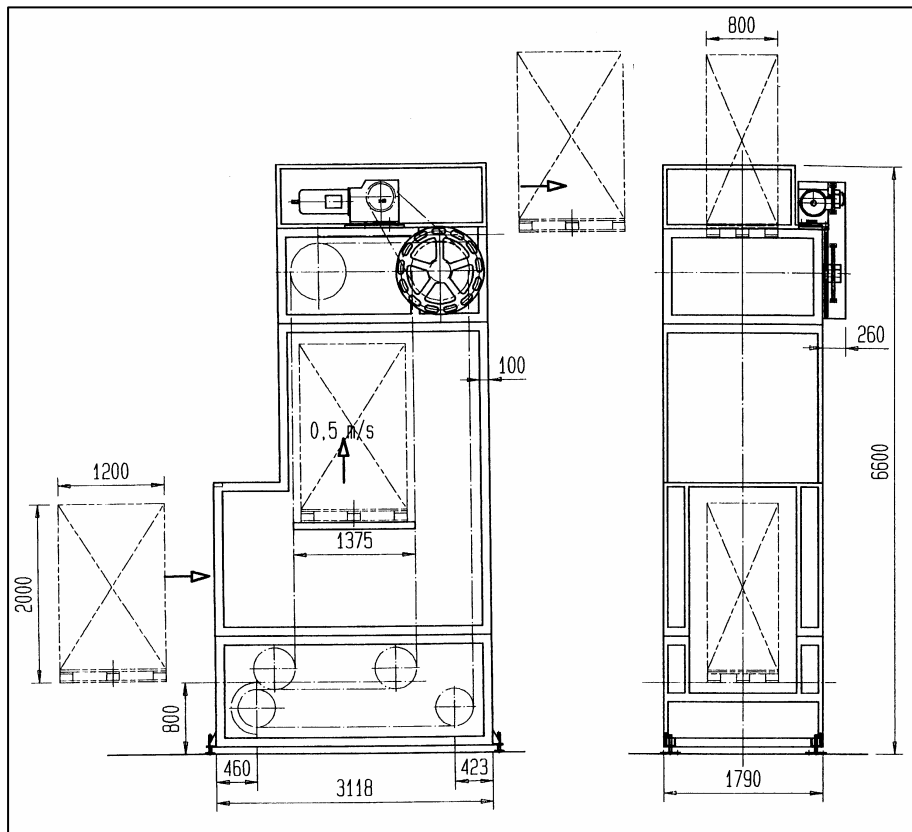

Dimensions (Example)

Exact dimensions depend on material, capacity and lifting height, and are obtainable on request.

Other brochures available for NERAK products:

- S-shaped conveyors
- Circulating conveyors
- Vertical lift units
- Circulating fork conveyors
- Reciprocating conveyors
- Heavy-duty reciprocating conveyors

NERAK GmbH Fördertechnik
Brigitta 5

29313 Hambühren

Tel.: 05084/944-0

Fax.: 05084/944-222

Email: info@nerak.de

Web: www.nerak.de