

NERAK RUBBER BLOCK CHAIN

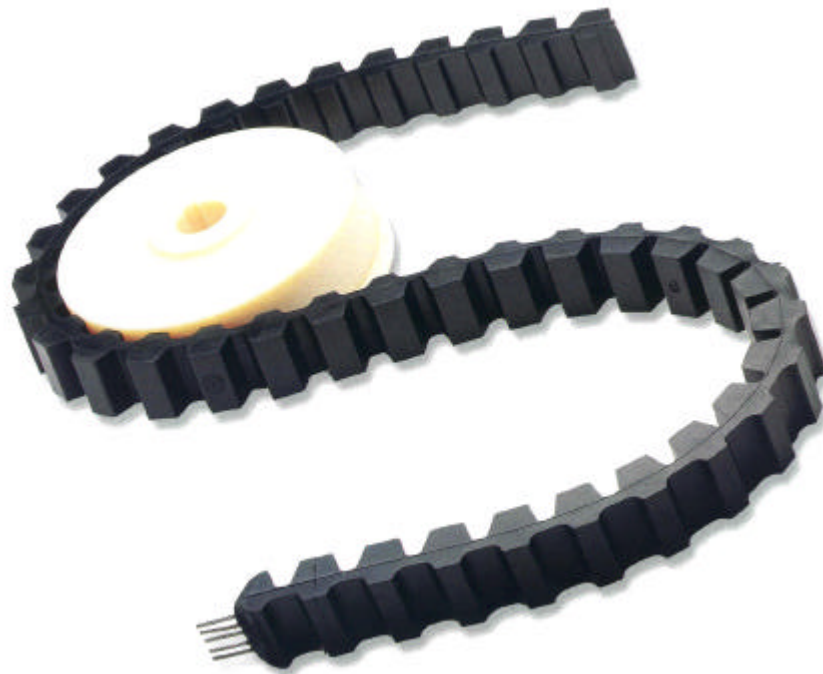

NERAK
FÖRDERTECHNIK

DRIVE SYSTEM

At the heart of every NERAK conveyor drive system is the heavy duty rubber block chain.

The rubber block chain is available in a variety of dimensions and in any length required to suit the particular application, whether for general or special equipment. It is supplied with the appropriate accessories such as wheels, rollers, attachments and suchlike.

The outstanding features of this chain are that it has no links, is silent-running, wear-resistant and virtually maintenance free, all excellent qualities further enhanced by its: **corrosion-free design.**



Thanks to the silent operation of the rubber block chain, there is no noise annoyance at the workstations in the immediate vicinity of the conveyor.

Moreover, operation with the rubber block chain is extremely cost-effective as there is no need for lubrication, regular adjustment and re-tensioning. Maintenance costs are thus reduced to a minimum.

The rubber block chain together with its roller-tooth drive wheels permits exact belt tracking and speed control.

The rubber block chain is available in a number of rubber compounds to suit every application. Where oily environments are concerned, preference is given to the abrasive-resistant SBR compounds or neoprene. For special applications and use in the foodstuff industry, the chain is available in white Buna N compounds. The rubber block chain gets its high tensile strength from embedded vulcanized steel cables.

Whatever your requirement, we can provide you with the optimum solution!

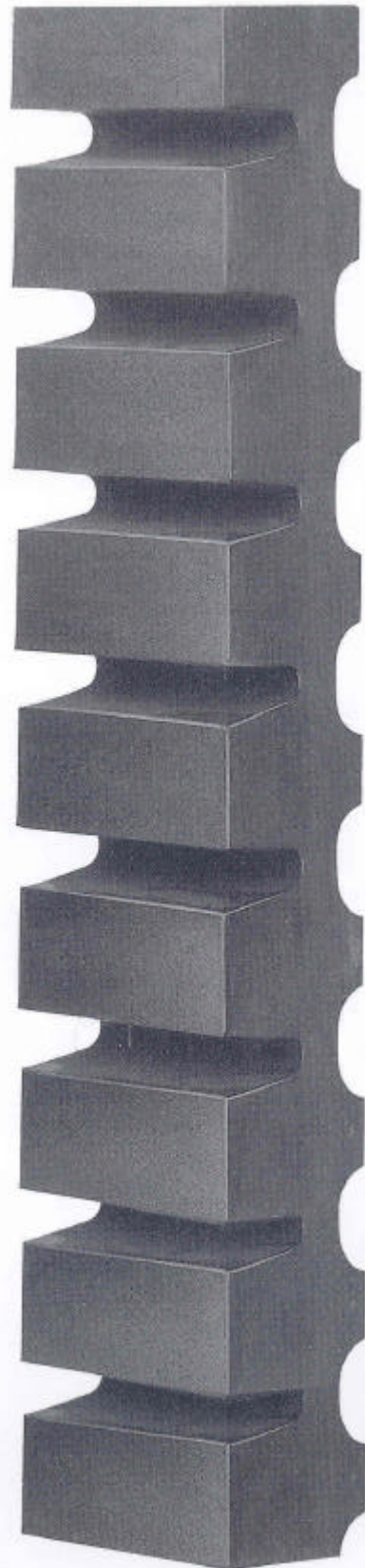

Gummiblockketten

Rubber block chain

GBK

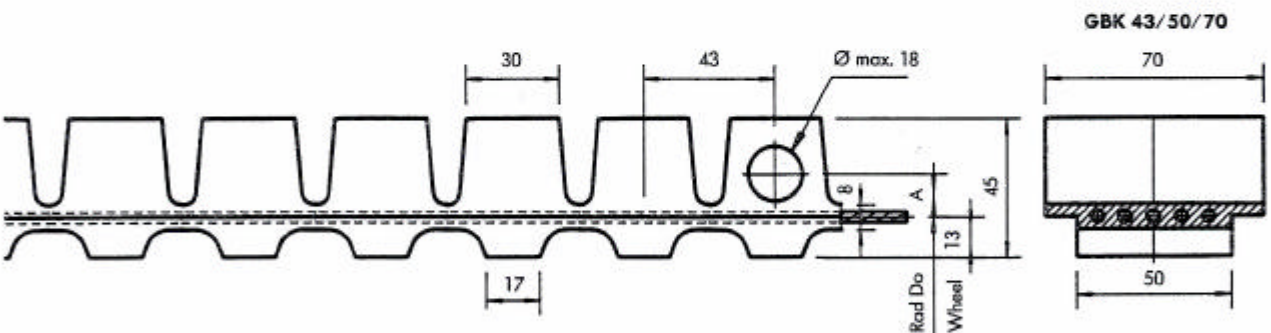
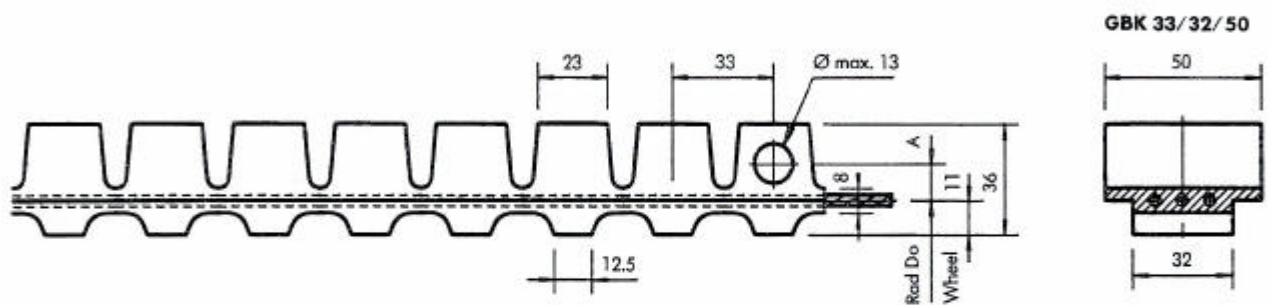
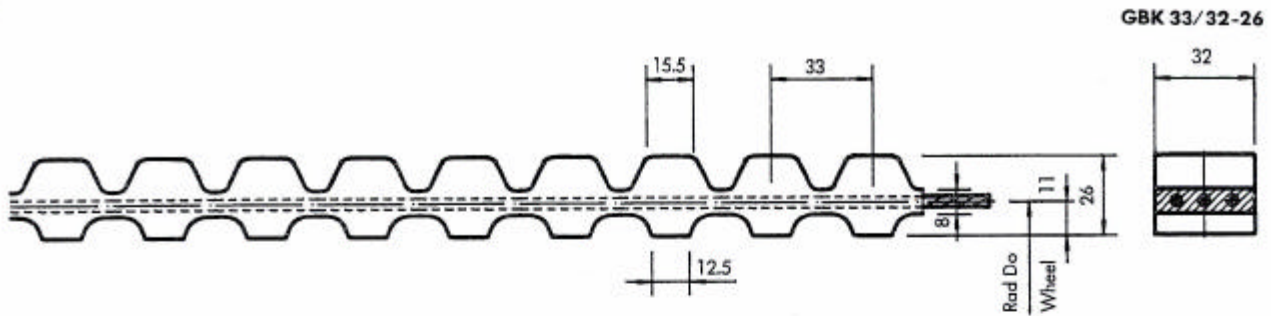

Bohrtabelle/ Table of drilling sizes

Ø	6	7	8	9	10	11	12	13	14	15	16	17	18
A	8	8.5	9	9.5	10	10.5	11	11.5	12	12.5	13	13.5	14

Zulässige Zugbelastung
pro Gummiblockkette:
lfm. Gewicht:

Maximum tension
per rubber chain:
Weight per metre:

GBK 33/32-26
5000 N
0,90 kg

GBK 33/32/50
5000 N
1,45 kg

GBK 43/50/70
8500 N
2,50 kg

Gummiqualität: SBR (Standard), auf Wunsch andere Qualitäten lieferbar.
Verzinkte Stahlseile Ø 3.42, max. Festigkeit: 12000 N pro Seil, Seiltellung: 9 mm.
Max. Dehnung: 0.5%, zulässige Temperatur: -30 + 90° C, Shore Härte: 65-70°.

Rubber type: SBR standard. Available in various qualities.
Load carrying steel wires Ø 3.42. Max. wire tension: 12000 N. Wire centre distance: 9 mm.
Max. elongation: 0.5%. Max. temperature: -30 + 90° C. 65-70° shore hardness.

Gummiblockketten

Rubber block chain

GBK

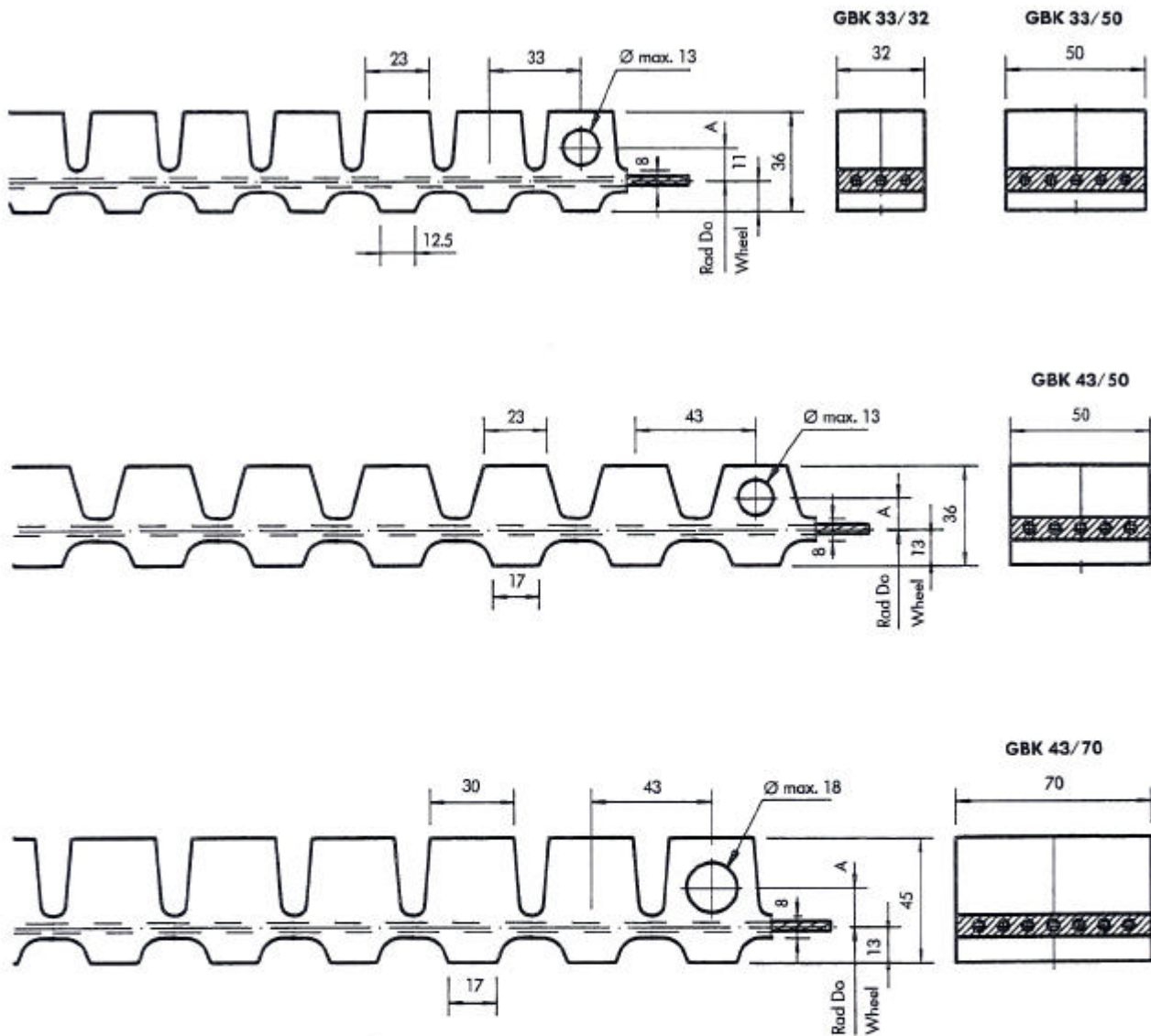

Bohrtabelle/ Table of drilling sizes

\varnothing	6	7	8	9	10	11	12	13	14	15	16	17	18
A	8	8.5	9	9.5	10	10.5	11	11.5	12	12.5	13	13.5	14

Zulässige Zugbelastung
pro Gummiblockkette:
lfm. Gewicht:

Maximum tension
per rubber chain:
Weight per metre:

GBK 33/32
5000 N
1,10 kg

GBK 33/50
8500 N
1,80 kg

GBK 43/50
8500 N
1,56 kg

GBK 43/70
12000 N
2,90 kg

Gummiqualität: SBR (Standard), auf Wunsch andere Qualitäten lieferbar.
Verzinkte Stahlseile \varnothing 3.42, max. Festigkeit: 12000 N pro Seil, Seilteilung: 9 mm.
Max. Dehnung: 0.5%, zulässige Temperatur: $-30 + 90^{\circ}$ C, Shore Härte: 65-70°.

Rubber type: SBR standard. Available in various qualities.
load carrying steel wires \varnothing 3.42. Max. wire tension: 12000 N. Wire centre distance: 9 mm.
Max. elongation: 0.5%. Max. temperature: $-30 + 90^{\circ}$ C. 65-70° shore hardness.

Gummiblockketten Rubber block chain GBK

Lösbare Verbindung, Scharnierverbindung
Hinging link connections

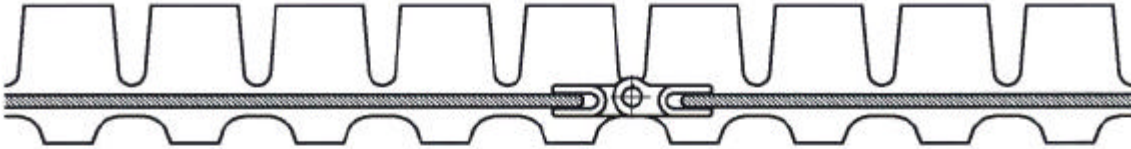

Stahlseil
Steel wires

V2A-Scharnierteil einvulkanisiert
Vulcanised st.stl. insert in halves

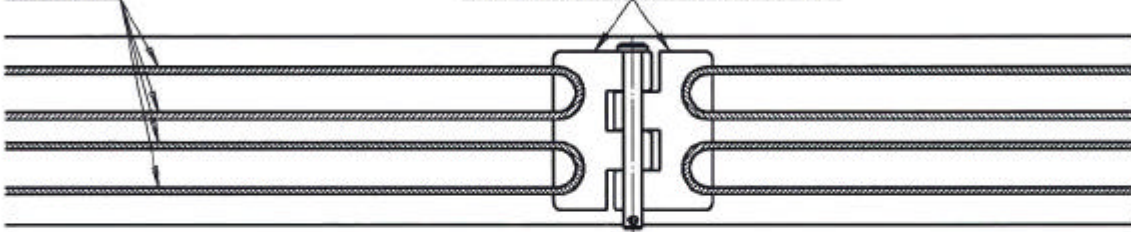

Endlosverbindung, Alu-Preßverbindung
Vulcanised endless connection

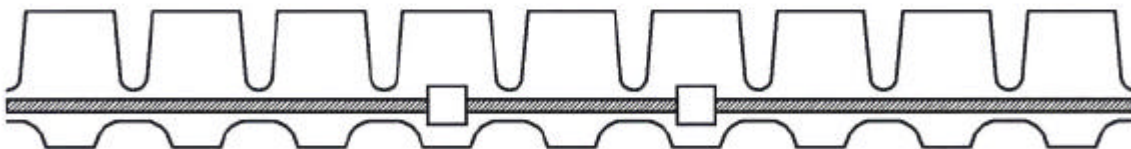

Stahlseil
Steel wires

Aluminiumpreßteil
Aluminium wire bidge

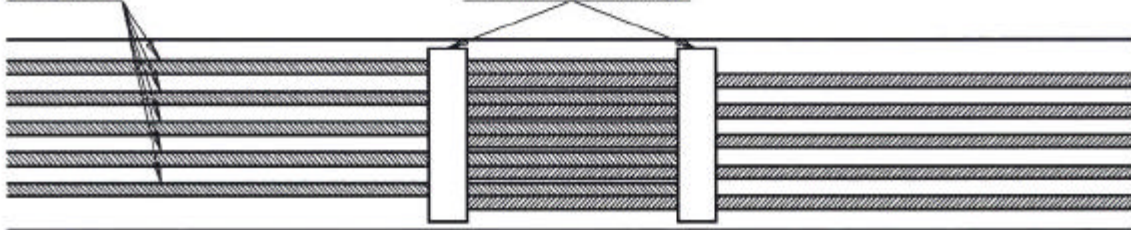

Antriebsräder Drive Wheel

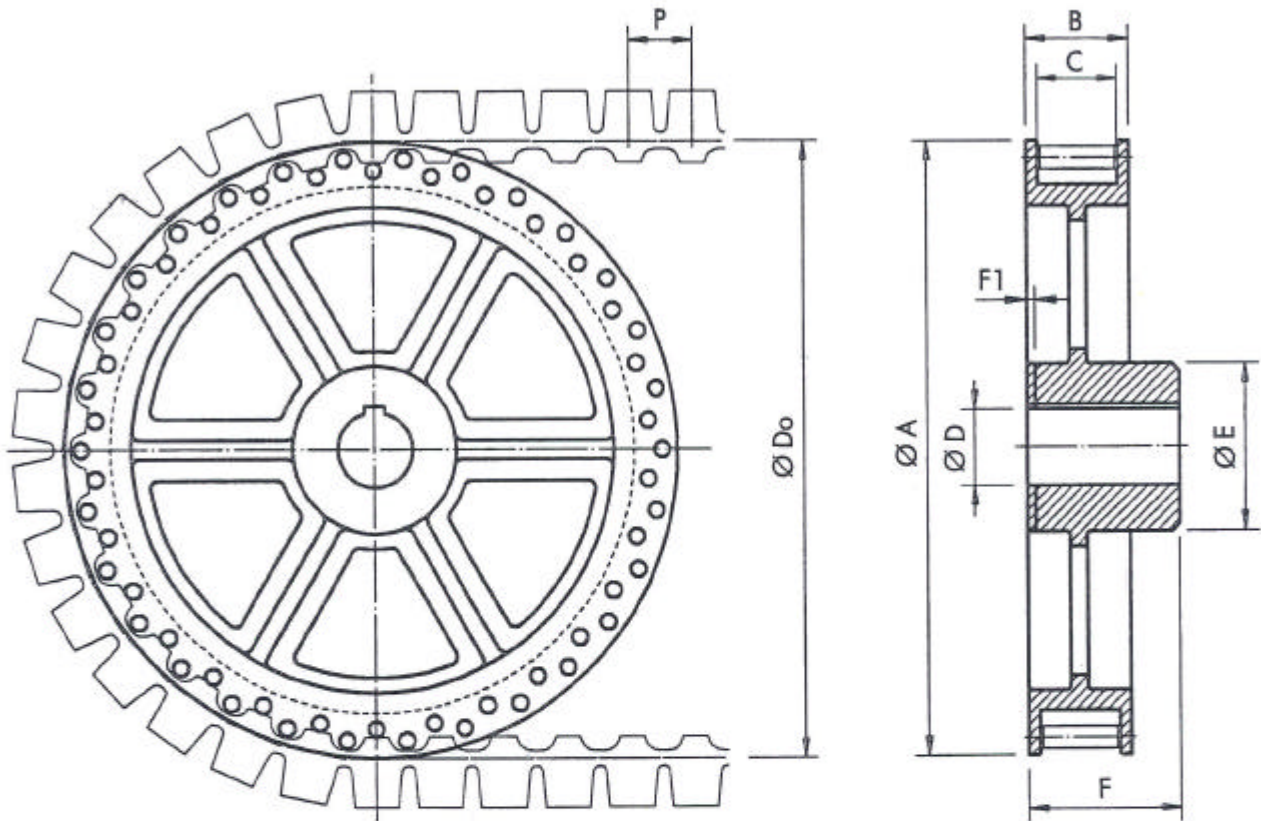

Type	Gummikette Rubber Chain	Ø Do	Ø A	B	C	Ø D	Ø E	F	F1	P
A 169/32/Z16	33/32	169	164	49	35	30	65	54		33
A 169/50/Z16	33/50	169	164	69	53	30	65	69		33
A 245/50/Z18	43/50									43
A 253/32/50/Z24	33/32 33/32/50	253	250	49	35	50	80	62.5	2.5	33 33
A 253/50/Z24	33/50	253	250	70	53	50	80	70		33
A 315/32/Z30	33/32 33/32/50	315	312	49	35	50	80	65		33 33
A 315/50/Z30	33/50	315	312	70	53	50	80	70		33
A 316/50/Z23	43/30	316	312	70	53	50	80	70		43
A 411/50/Z30	43/30 43/50/70	411	406	70	53	70	110	100		43 43
A 411/70/Z30	43/70	411	406	100	73	70	110	100		43

Umlenkräder Idler Wheel

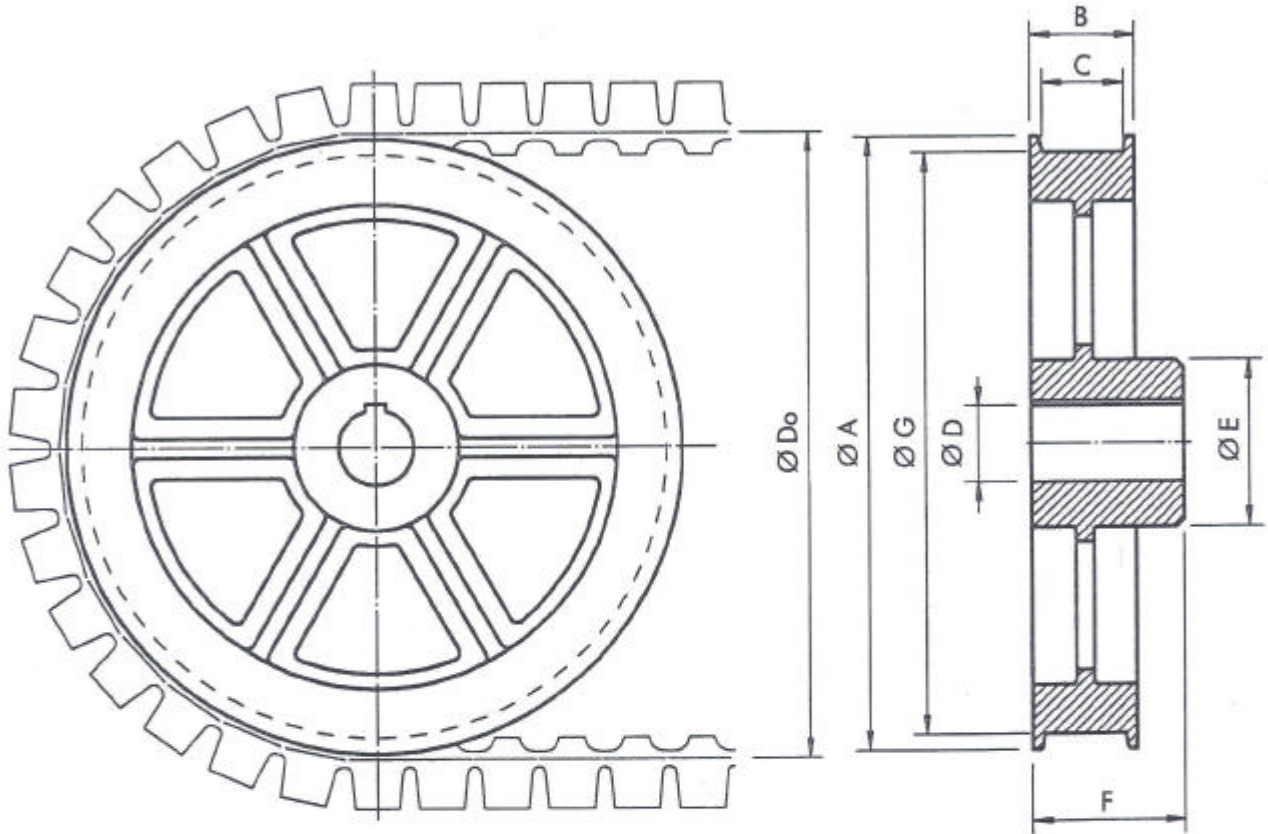

Type	Gummikette Rubber Chain	$\varnothing D_o$	$\varnothing A$	B	C	$\varnothing D$	$\varnothing E$	F	$\varnothing G$
U 169/32	33/32	169	160	44	35	30	60	54	147
U 169/50	33/50	169	160	70	54	30	60	70	147
U 253/32	33/32 33/32/50	253	250	45	34	40	80	60	230
U 253/50	33/50	253	250	70	54	40	80	70	230
U 315/32	33/32 33/32/50	315	312	49	34	40	80	70	294
U 315/50	33/50	315	312	70	54	40	80	70	294
U 316/50	43/50	316	312	70	54	40	80	70	290
U 411/50	43/50	411	406	70	53	50	110	100	385
	43/50/70								
U 411/70	43/70	411	406	90	73	60	110	100	385

Führungsräder Inverse Idler Wheel

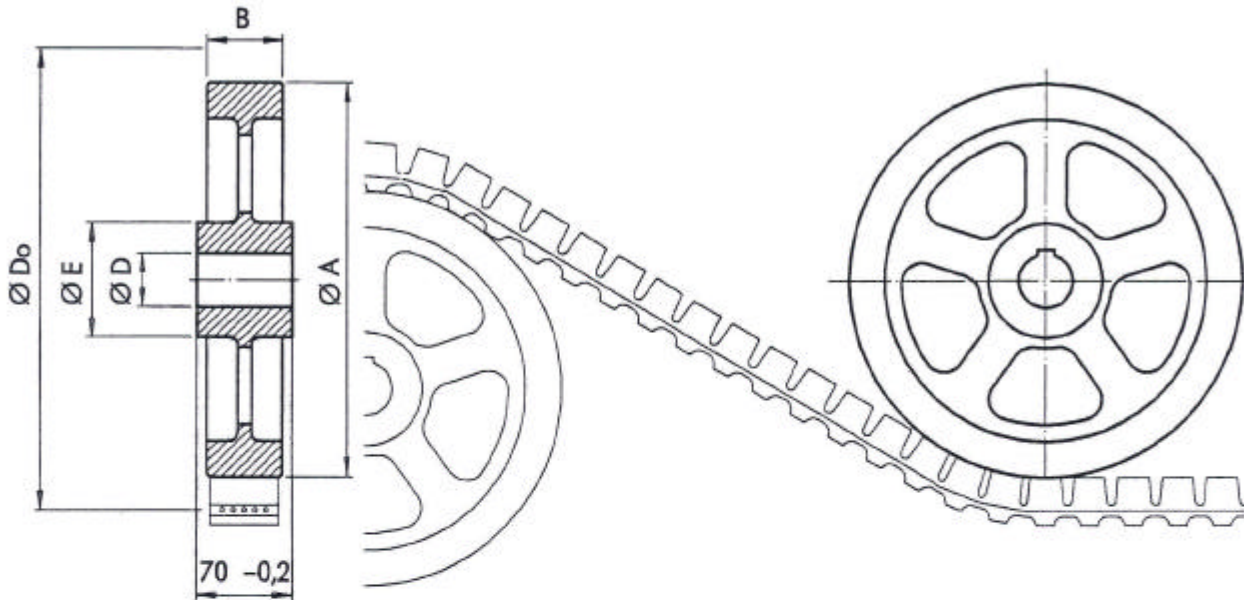

Type	Gummikette Rubber Chain	Ø Do	Ø A	B	Ø D	Ø E	
F 200	33/50	197	147	55	40	65	
	33/32/50	197	147	55	40	65	
	43/50	193	147	55	40	65	
F 280	33/32	280	230	35	40	80	
F 276	43/50	276	230	55	40	80	
F 344	33/50	344	294	55	40	80	
	33/32/50	344	294	55	40	80	
	43/50	340	294	55	40	80	
F 435	33/50	435	385	55	50	80	
	33/32/50	435	385	55	50	80	
	43/50	431	385	55	50	80	
F 500	33/50	498	448	55	40	80	
	33/32/50	498	448	55	40	80	
	43/50	495	448	55	40	80	



Example of the rubber block chain used as travelling gear.

Other favoured areas of application:

- Sewage treatment plants
- Sorting plants
- Foundries
- Special plant construction

NERAK GmbH Fördertechnik
Brigitta 5

29313 Hambühren

Tel.: 05084/944-0
Fax.: 05084/944-222
Email: info@nerak.de
Web: www.nerak.de

r:\tb\dok_ne\gummiblockkette\prospekt\gb\gbk_prospekt_gb.doc